

UMENT AND THE INFORMATION IT  
HAVE BEEN FURNISHED FOR USE  
BY YOUR OWN ORGANIZATION ONLY AND  
NOT FOR REPRODUCTION OR TRANSMISSION  
IN ANY MANNER WITHOUT THE WRITTEN  
CONSENT OF KANSAS CITY DEAERATOR CO.,  
OVERLAND PARK, KANSAS 66209

NO.	DATE	DESCRIPTION OF CHANGE
-	-	-
-	-	-
-	-	-
-	-	-

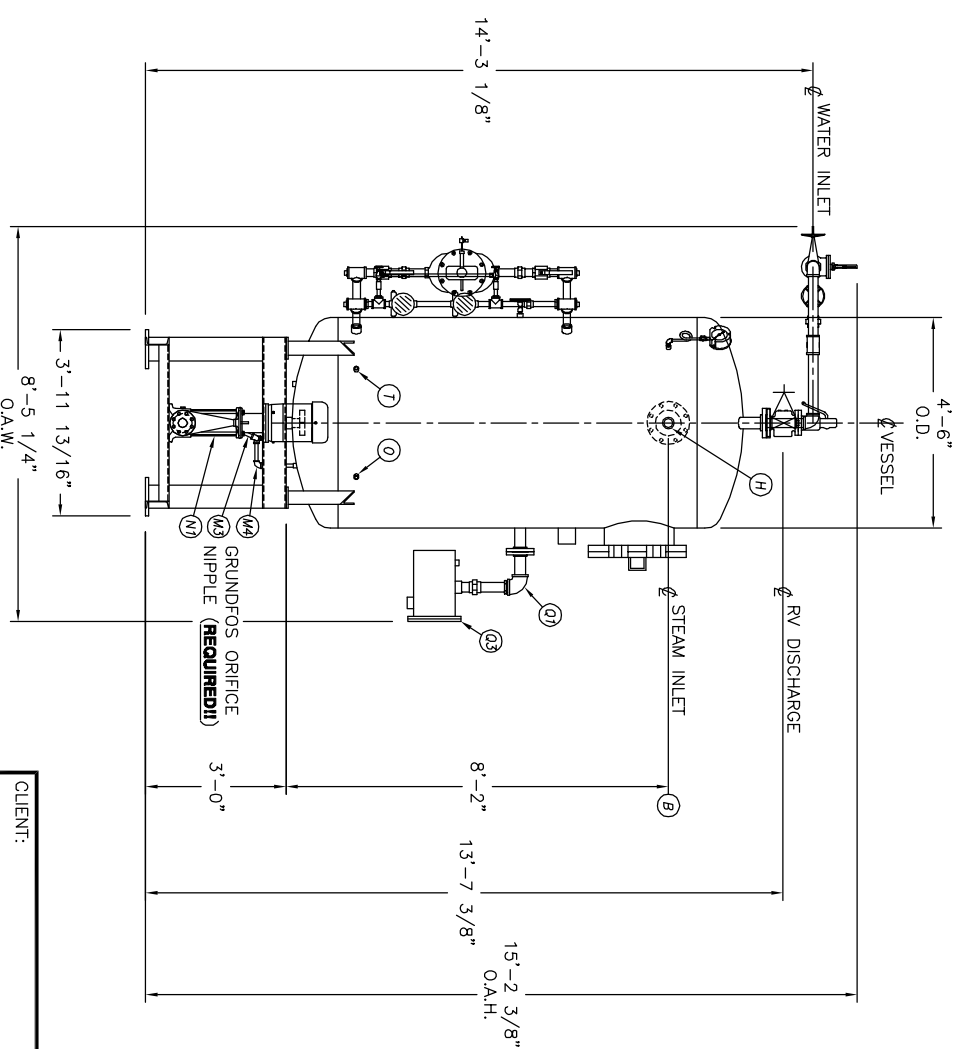
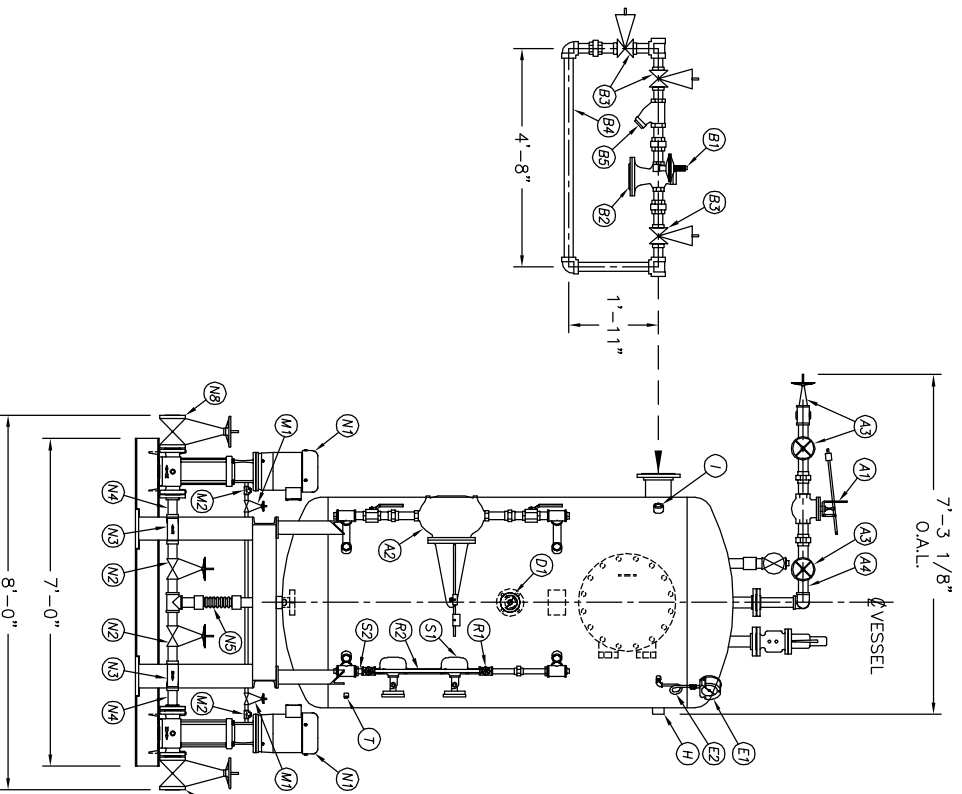
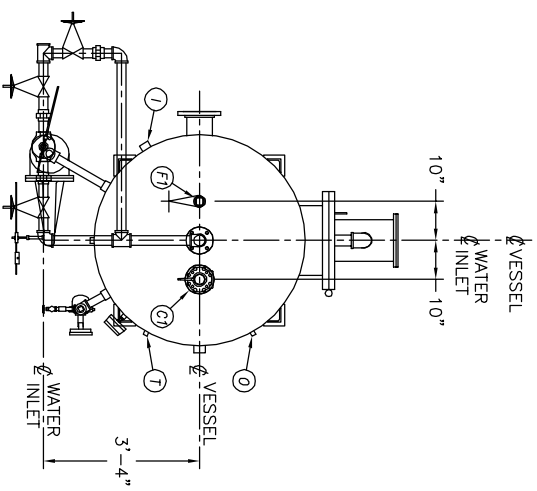

A1	INLET VALVE	NONE	
A2	CONTROL VALVE	NONE	
A3	BYPASS VALVES	NIBCO	T-111
A4	MAKE UP BY-PASS PIPING	KOD SHOP	
A5	STRAINER	NONE	
B1	STEAM PRV	NONE	
B2	STEAM CONTROLLER	NONE	
B3	BYPASS VALVES	NONE	
B4	STEAM PRV BY-PASS PIPING	NONE	
B5	1 STRAINER	MUELLER	752
C1	RELIEF VALVE	NONE	
C2	RELIEF VALVE PIPING	NONE	
D1	THERMOWELL	NONE	
E1	PRESSURE GAUGE	NONE	
E2	SIPHON & COCK	NONE	
E3	PRESSURE TRANS	NONE	
F1	VENT VALVE	NONE	
F2	1 ORIFICE PLATES	#N/A	
F3	BYPASS VALVES	NONE	
F4	VENT PIPING	NONE	
G1	IMV SPARE GASKETS	NONE	
H1	VACUUM BREAKER	NONE	
M1	BFP RECIRC SHUTTOFF		
M2	BFP RECIRC CHECK		
M3	BFP ORIFICE / VALVE		
M4	BFP PIPING	NONE	
M5	BFP PRESSURE GAUGE		
M6	BFP PRESSURE GAUGE		
M7	2 BOILER FEED PUMPS	GRUNDFOS	CR60-50U
N2	ISOLATION VALVE	NIBCO	F817.0
N3	2 STRAINER	MUELLER	758
N4	2 PIPING	4	KOD SHOP
N5	2 EXPANSION JOINT	4	
N6	BFP DISC PRESSURE GAUGE		
N7	BFP DISC CHECK		
N8	BFP DISCH ISOLATION		
O	CHEMICAL FEED QUILL	NONE	
P	IMV SPARE GASKETS		
Q1	OVERFLOW VALVE	NONE	
Q2	CONTROL VALVE	NONE	
Q3	OVERFLOW PIPING	NONE	
R1	LEVEL SWITCHES	NONE	
R2	1 LEVEL SWITCH BRIDLE PIPING	1 1/2	T-111
S1	GAUGE GLASS	NONE	
S2	1 GAUGE GLASS BRIDLE PIPING	1 1/2	T-111
T1			
2	CONTROL PANEL		
	STARTERS	NONE	
1	PUMP STAND	14.2	

**NOTES:**  
1. CUSTOMER TO FIELD ALIGN PUMPS AND MOTORS, THEN SEND KOD CERTIFICATION PAPERS.  
2. GROUT STAND AS NECESSARY.

CLIENT:	KANSAS CITY DEAERATOR CO. 6731 W. 121st STREET OVERLAND PARK, KANSAS 66209 (913) 338-2111 FAX (913) 338-2144					
JOB #	SCALE	DESIGNED	DRAWN	CHECKED	DATE	UTD
STD	NTS	MK	GENI	PC	12-15	12-15
TITLE: GENERAL ARRANGEMENT						2003
MODEL: VSP-4508-030						2003
DWG. NO: VSP4508-030-CR16-60						