

UMENT AND THE INFORMATION IT
HAVE BEEN FURNISHED FOR USE
BY OWN ORGANIZATION ONLY AND
NOT BE REPRODUCED OR TRANSMITTED
IN ANY FORM OR BY ANY MEANS
ELECTRONIC OR MECHANICAL,
INCLUDING PHOTOCOPYING, RECORDING,
OR BY ANY INFORMATION STORAGE
AND RETRIEVAL SYSTEM, WITHOUT
THE WRITTEN PERMISSION OF
KANSAS CITY DEAERATOR CO.,
1400 PARK, KANSAS 66209

NO.	DATE	DESCRIPTION OF CHANGE	BY
-	-	-	-
-	-	-	-
-	-	-	-

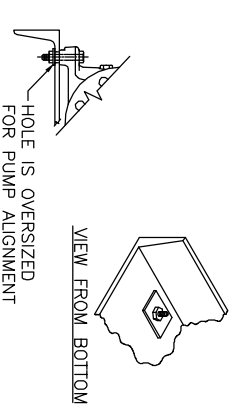
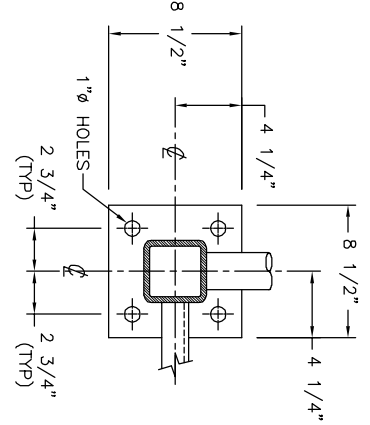
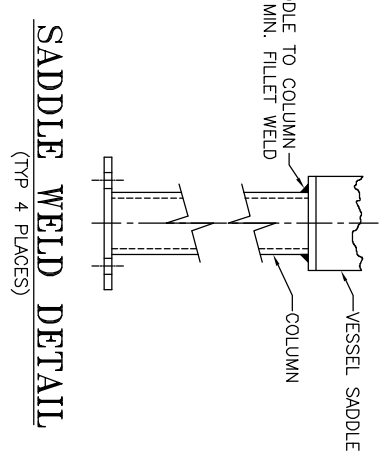
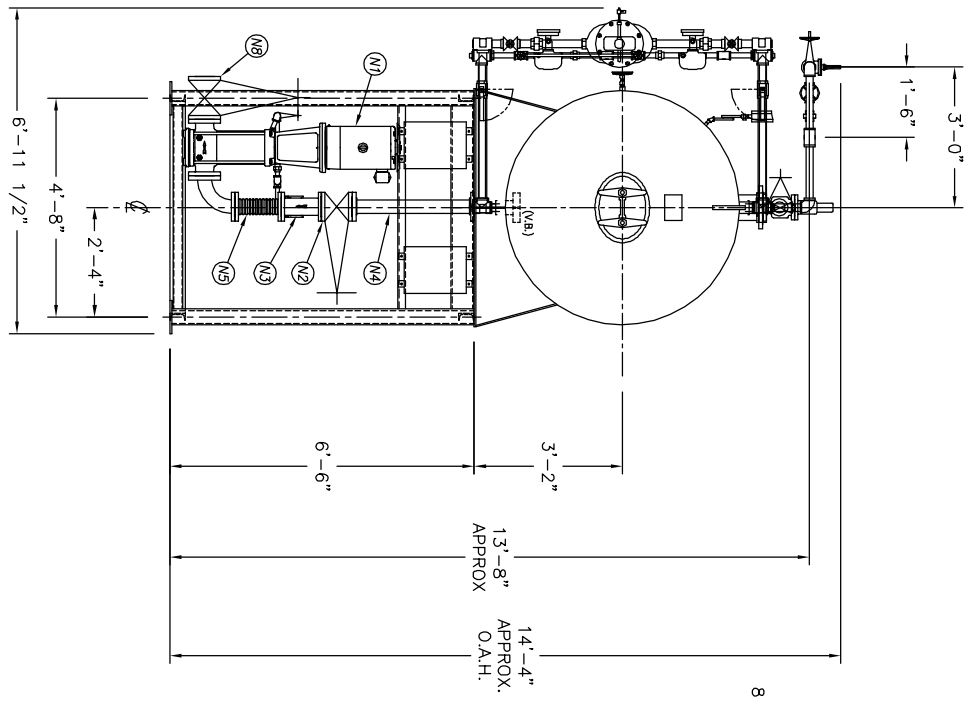
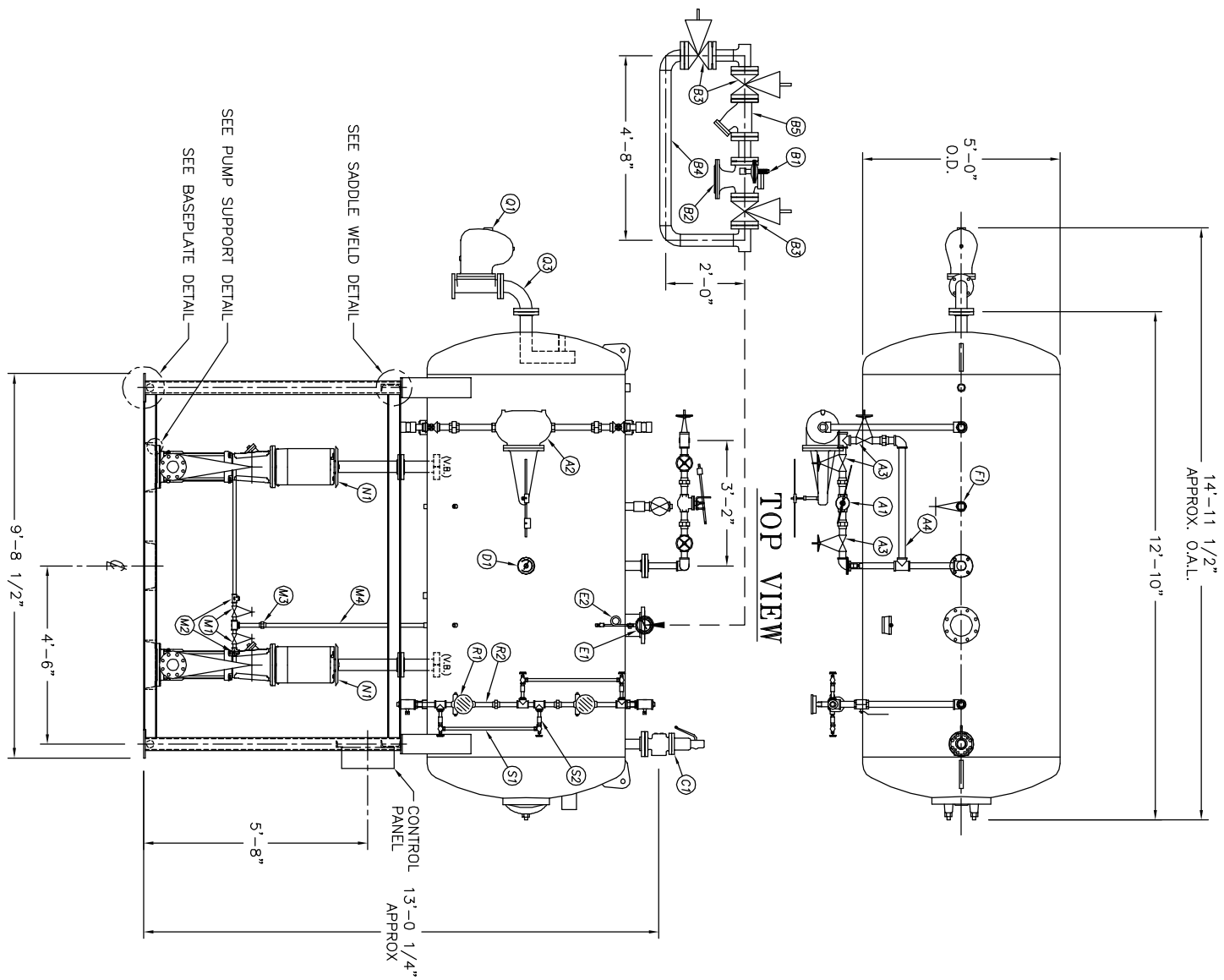

PUMP SUPPORT DETAIL

A1	INLET VALVE	NONE	NONE	
A2	CONTROLLER	NONE	NONE	
A3	BYPASS VALVES	2	NIBCO	T-111
A4	MAKE UP BY-PASS PIPING	2	KCD SHOP	
A5	STRAINER	NONE	NONE	
B1	STEAM PRV	NONE	NONE	
B2	STEAM CONTROLLER	NONE	NONE	
B3	BYPASS VALVES	NONE	NONE	
B4	STEAM PRV BY-PASS PIPING	3	MELLER	782
B5	1 STRAINER			
C1	RELIEF VALVE	NONE	NONE	
C2	RELIEF VALVE PIPING	NONE	NONE	
D1	THERMOMETER	NONE	NONE	
E1	PRESSURE GAUGE	NONE	NONE	
E2	SIPHON & COCK	NONE	NONE	
E3	PRESSURE TRANS	NONE	NONE	
F1	VENT VALVE	NONE	NONE	
F2	1 ORIFICE PLATES	#N/A	#N/A	
F3	BYPASS VALVES	NONE	NONE	
F4	VENT PIPING	NONE	NONE	
G1	1M7 SPARE GASKETS	NONE	NONE	
H1	VACUUM BREAKER	NONE	NONE	
M1	BFP REGICR SHUTOFF			
M2	BFP REGICR CHECK			
M3	BFP ORIFICE / VALVE			
M4	BFP PIPING	NONE	NONE	
M5	BFP PRESSURE GAUGE	4	GRUNDFOC	CR80-50U
N1	2 BOILER FEED PUMPS	4	NIBCO	FB17-0
N2	2 ISOLATION VALVE	4	MELLER	788
N3	2 STRAINER	4	KCD SHOP	
N4	2 PIPING	4		
N5	2 EXPANSION JOINT	4		
N6	BFP DISC PRESSURE GAUGE			
N7	BFP DISC CHECK			
N8	BFP DISCH ISOLATION			
O	CHEMICAL FEED QUILL	NONE	NONE	
P	1M7 SPARE GASKETS			
Q1	OVERFLOW VALVE	NONE	NONE	
Q2	CONTROLLER	NONE	NONE	
Q3	OVERFLOW PIPING	NONE	NONE	
R1	LEVEL SWITCHES	1 1/2	NIBCO	T-111
R2	LEVEL SWITCH BRIDLE PIPING	1 1/2	NONE	
S1	GAUGE GLASS	1 1/2	NONE	
S2	1 GAUGE GLASS BRIDLE PIPING	1 1/2	NIBCO	T-111
T1				
2	CONTROL PANEL	NONE		
	STARTERS	NONE		
1	PUMP STAND	14.2		

NOTE:
CUSTOMER TO FIELD ALIGN PUMPS
AND MOTORS, THEN SEND KCD
CERTIFICATION PAPERS.

CLIENT: **KANSAS CITY DEAERATOR CO.**
6731 W. 121st STREET
OVERLAND PARK, KANSAS 66209
(913) 338-2111 FAX (913) 338-2144

JOB #	SCALE	DESIGNED	DRAWN	CHECKED	DATE	UTD
STD	NTS	MK	GENI	PC	8-14 2003	8-14 2003

TITLE: **GENERAL ARRANGEMENT PACKAGE - HS5010**
MODEL: HS5010-065-CR45-4

DWG. NO.: **HS5010-065-CR45-4**