

- NOTES:**
- SEE CONNECTION SCHEDULE FOR NOZZLE DESCRIPTIONS.
  - STRAIGHT LENGTHS ARE APPROXIMATE. OVERALL LENGTH (OAL) IS TO BE HELD.
  - FOR MISCELLANEOUS DETAILS SEE MD DRAWINGS
  - DIMENSIONS ARE GIVEN FROM CENTER LINE OF TANKS TO NOZZLE CENTER LINE OR OUTSIDE FACE OF FLANGE.
  - G.B. = GRAB BAR  
V.B. = VORTEX BREAKER  
N.P. = NAME PLATE  
F.S. = FAR SIDE
  - D.S. = DRIP SHIELD  
N.S. = NEAR SIDE  
T.B. = TEE Baffle  
CL = CENTER LINE

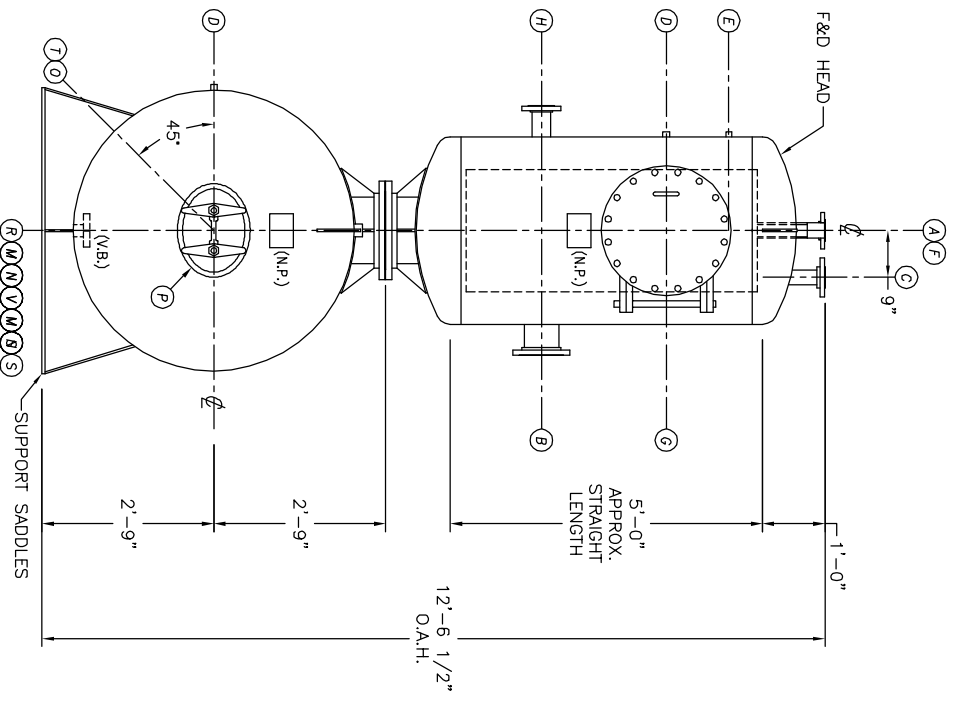
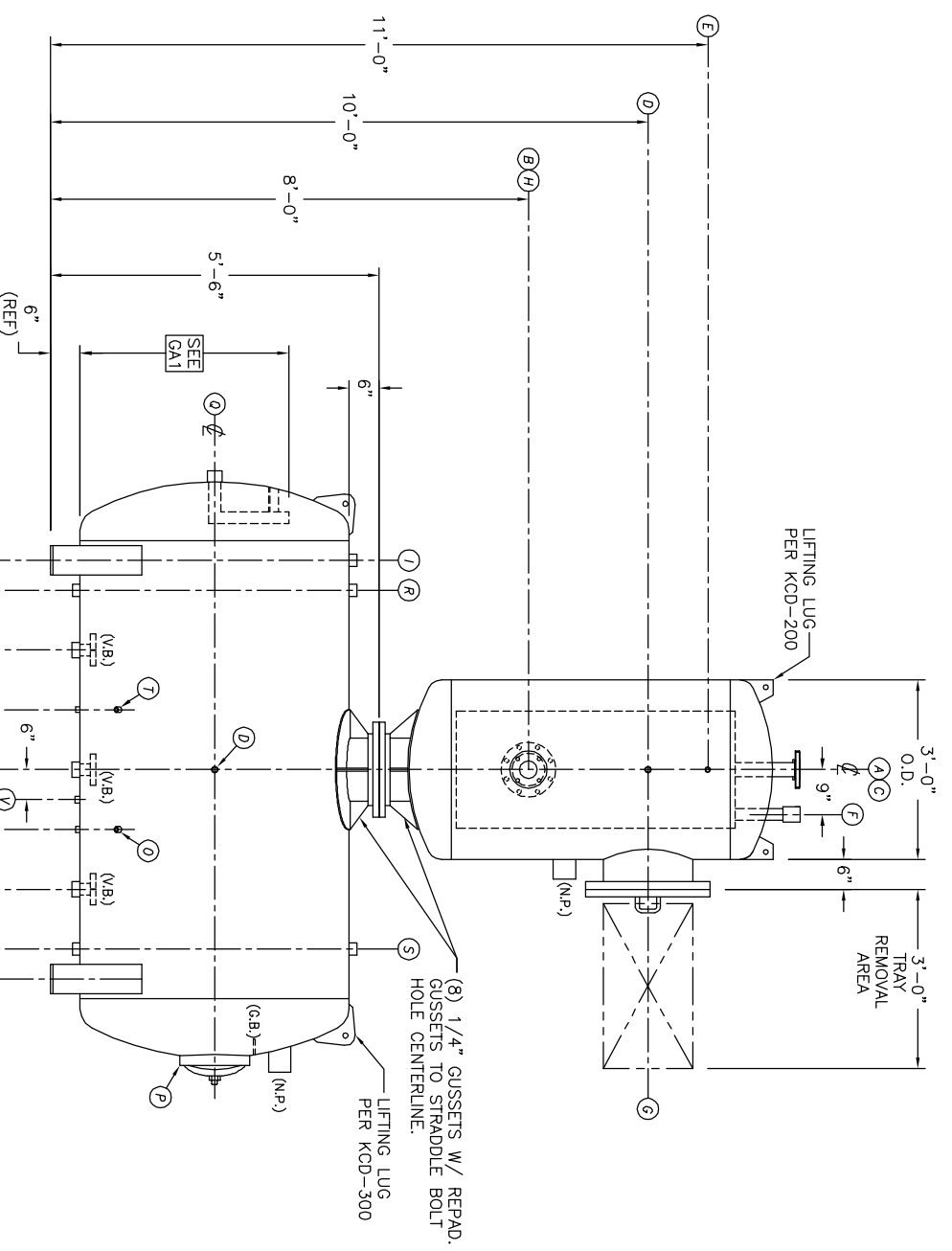
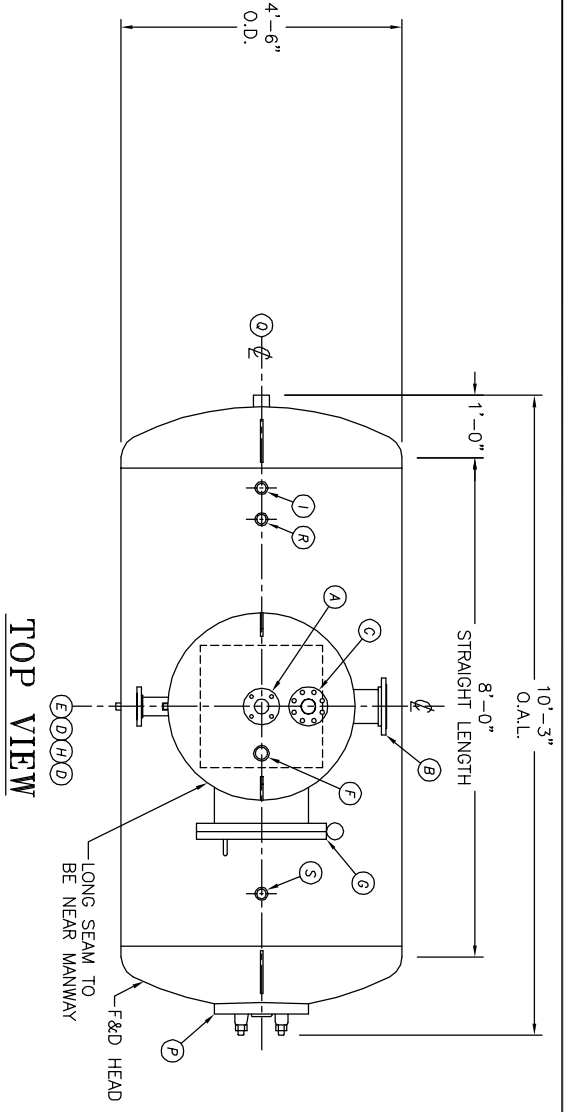

**NOTE:**  
PUMP SUCTION NOZZLES WILL BE ADDED TO MATCH ANY PUMPS SUPPLIED BY KCD

Click Here & Upgrade  
Expanded Features  
Unlimited Pages

**PDF Complete**

UMENT AND THE INFORMATION IT HAVE BEEN FURNISHED FOR USE & OWN ORGANIZATION ONLY AND PURPOSE CONSISTENT WITH THE ON BETWEEN YOUR ORGANIZATION SAS CITY DEARATOR COMPANY. IT SHALL BE FURNISHED TO ANY PARTY WITHOUT THE WRITTEN OF KANSAS CITY DEARATOR CO., LAND PARK, KANSAS 66209

NO.	DATE	DESCRIPTION OF CHANGE
-	-	-
-	-	-
-	-	-

CLIENT:

**KANSAS CITY DEARATOR CO.**  
6731 W. 121st STREET  
OVERLAND PARK, KANSAS 66209  
(913) 338-2111 FAX (913) 338-2144

JOB #	SCALE	DESIGNED	DRAWN	CHECKED	DATE	UTD
STD	NTS	MK	GENI	PC	6-08 2004	6-08 2004

TITLE: **GENERAL ARRANGEMENT**

MODEL: **BDSP50-4508**

DWG. NO.: **BDSP50-4508**